

Junior:

Design Documentation

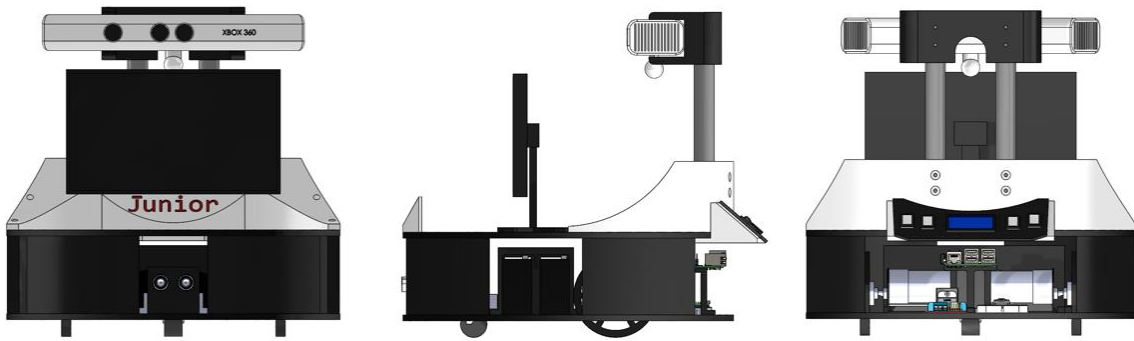

Authors: Reed Johnson, Nathan Kong, Amer Safdari, Rebecca Smith

Contents:

- (1) Bill of Materials
- (2) Drawings of custom parts designed for the robot

Note: The drawings are not complete with all dimensions. Important dimensions are displayed.

Junior:			
Bill of Materials:			
Item #:	Part Name:	Quantity:	Source:
1	Bottom Chassis	1	Laser cut
2	Top Chassis	1	Laser cut
3	Junior Sides	1	3D Printed
4	Nameplate	1	3D Printed
5	Ultrasonic Mount	1	3D Printed
6	Battery Holder	1	3D Printed
7	Rod Holder	1	3D Printed
8	UP Board Mount	1	3D Printed
9	Switchboard	1	3D Printed
10	Switchboard Panel	1	Laser cut
11	Kinect Mount	1	3D Printed
12	Kinect Poles	1	PVC Pipe
13	Caster Wheel	1	AX Man
14	Wheel	2	Amazon
15	DC Motor	2	Amazon
16	Motor Bracket	2	Amazon
17	Ultrasonic Sensor	1	Amazon
18	12v Battery	2	Amazon
19	Breadboard	1	Amazon
20	Teensy 3.5	1	Amazon
21	Motor Driver	1	Amazon
22	UP Board	1	UP-Board.com
23	Microsoft Kinect	1	Amazon
24	Voltage monitor	1	Amazon

4

3

2

1

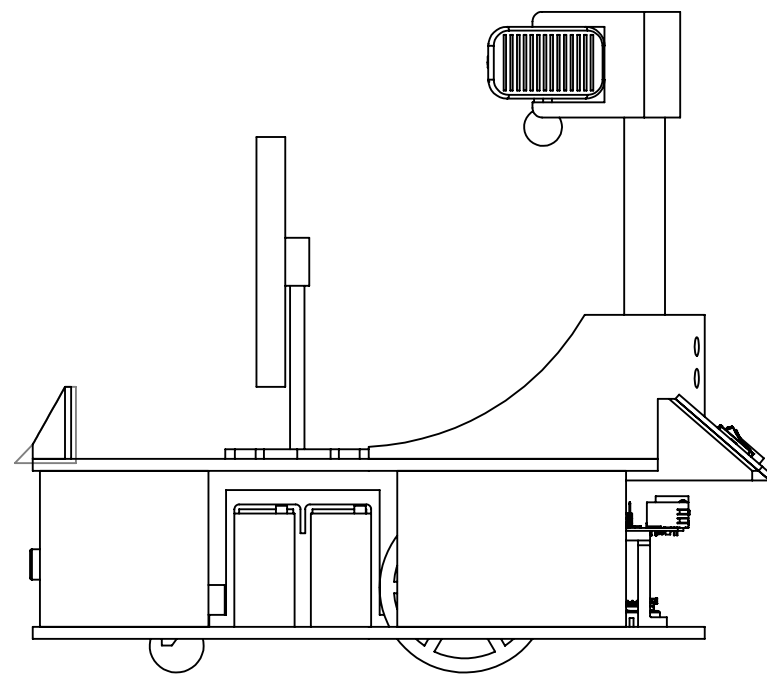
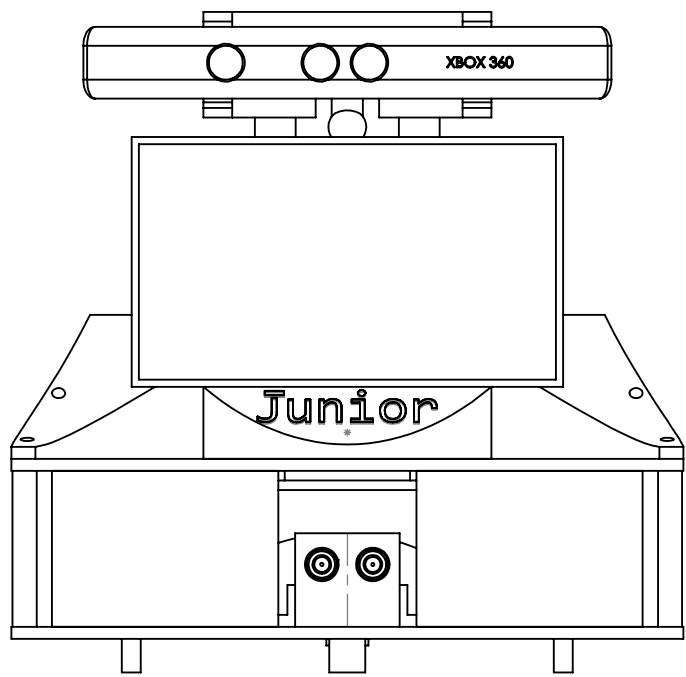
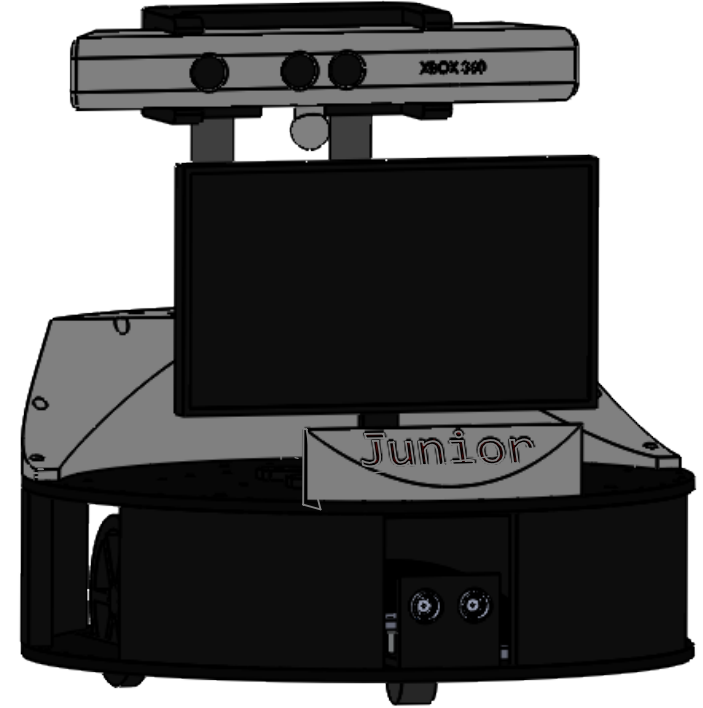
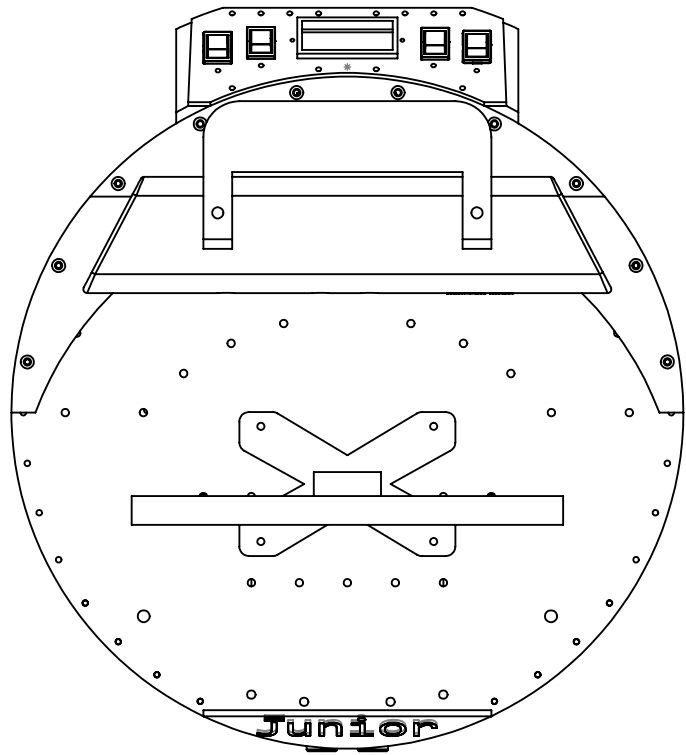

B

B

A

A

PROPRIETARY AND CONFIDENTIAL
 THE INFORMATION CONTAINED IN THIS DRAWING IS THE SOLE PROPERTY OF <INSERT COMPANY NAME HERE>. ANY REPRODUCTION IN PART OR AS A WHOLE WITHOUT THE WRITTEN PERMISSION OF <INSERT COMPANY NAME HERE> IS PROHIBITED.

		UNLESS OTHERWISE SPECIFIED:	NAME	DATE			
		DIMENSIONS ARE IN INCHES	DRAWN		TITLE:		
		TOLERANCES:	CHECKED				
		FRACTIONAL ±	ENG APPR.				
		ANGULAR: MACH ± BEND ±	MFG APPR.				
		TWO PLACE DECIMAL ±	Q.A.				
		THREE PLACE DECIMAL ±	COMMENTS:				
		INTERPRET GEOMETRIC TOLERANCING PER:			SIZE	DWG. NO.	REV
		MATERIAL			B	Full Assem	
NEXT ASSY	USED ON	FINISH			SCALE: 1:5	WEIGHT:	SHEET 1 OF 1
APPLICATION		DO NOT SCALE DRAWING					

4

3

2

1

4

3

2

1

B

B

A

A

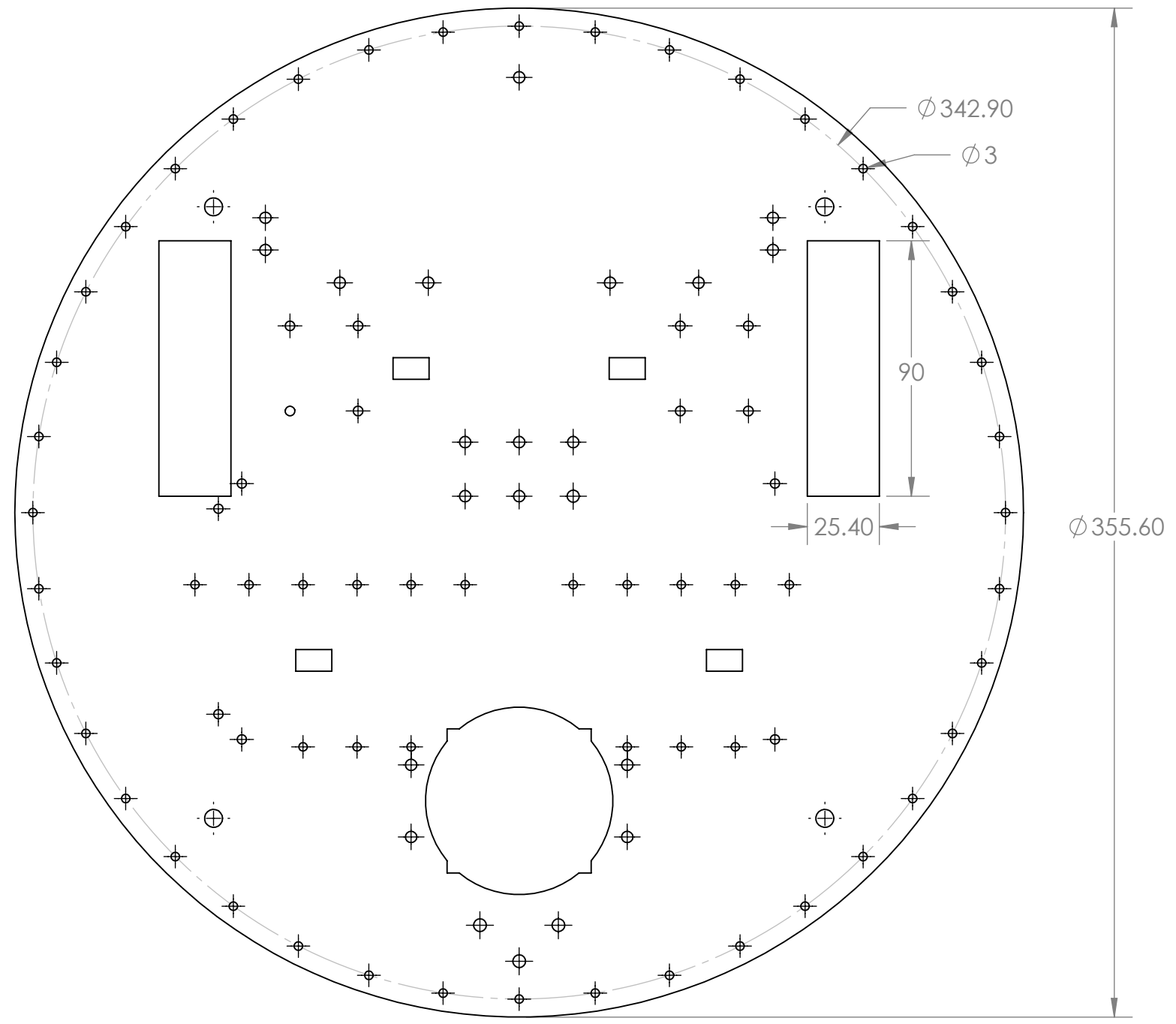

6.35

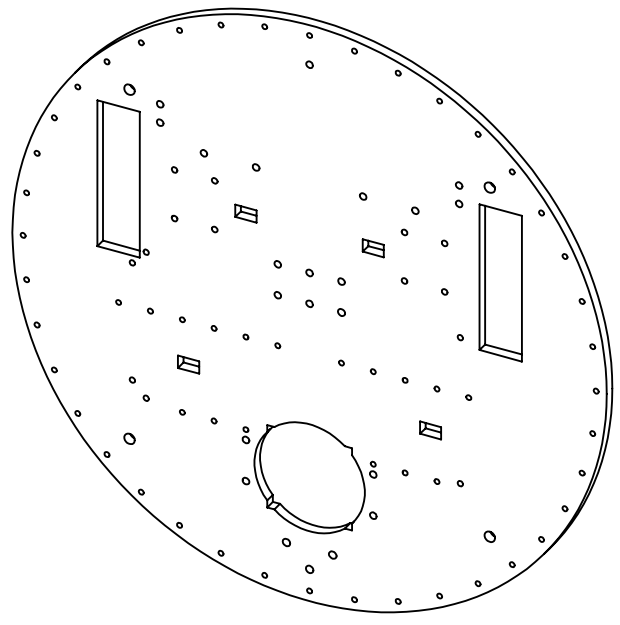
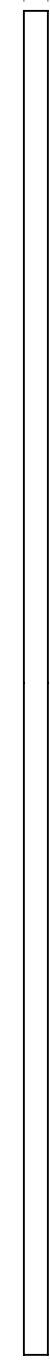

PROPRIETARY AND CONFIDENTIAL
 THE INFORMATION CONTAINED IN THIS DRAWING IS THE SOLE PROPERTY OF <INSERT COMPANY NAME HERE>. ANY REPRODUCTION IN PART OR AS A WHOLE WITHOUT THE WRITTEN PERMISSION OF <INSERT COMPANY NAME HERE> IS PROHIBITED.

		UNLESS OTHERWISE SPECIFIED:	NAME	DATE		
		DIMENSIONS ARE IN INCHES	DRAWN			
		TOLERANCES:	CHECKED		TITLE:	
		FRACTIONAL \pm	ENG APPR.			
		ANGULAR: MACH \pm BEND \pm	MFG APPR.			
		TWO PLACE DECIMAL \pm	Q.A.			
		THREE PLACE DECIMAL \pm	COMMENTS:			
		INTERPRET GEOMETRIC TOLERANCING PER:				
		MATERIAL				
NEXT ASSY	USED ON	FINISH	SIZE	DWG. NO.	REV	
APPLICATION		DO NOT SCALE DRAWING	B	Bottom Chassis		
			SCALE: 1:2	WEIGHT:	SHEET 1 OF 1	

4

3

2

1

4

3

2

1

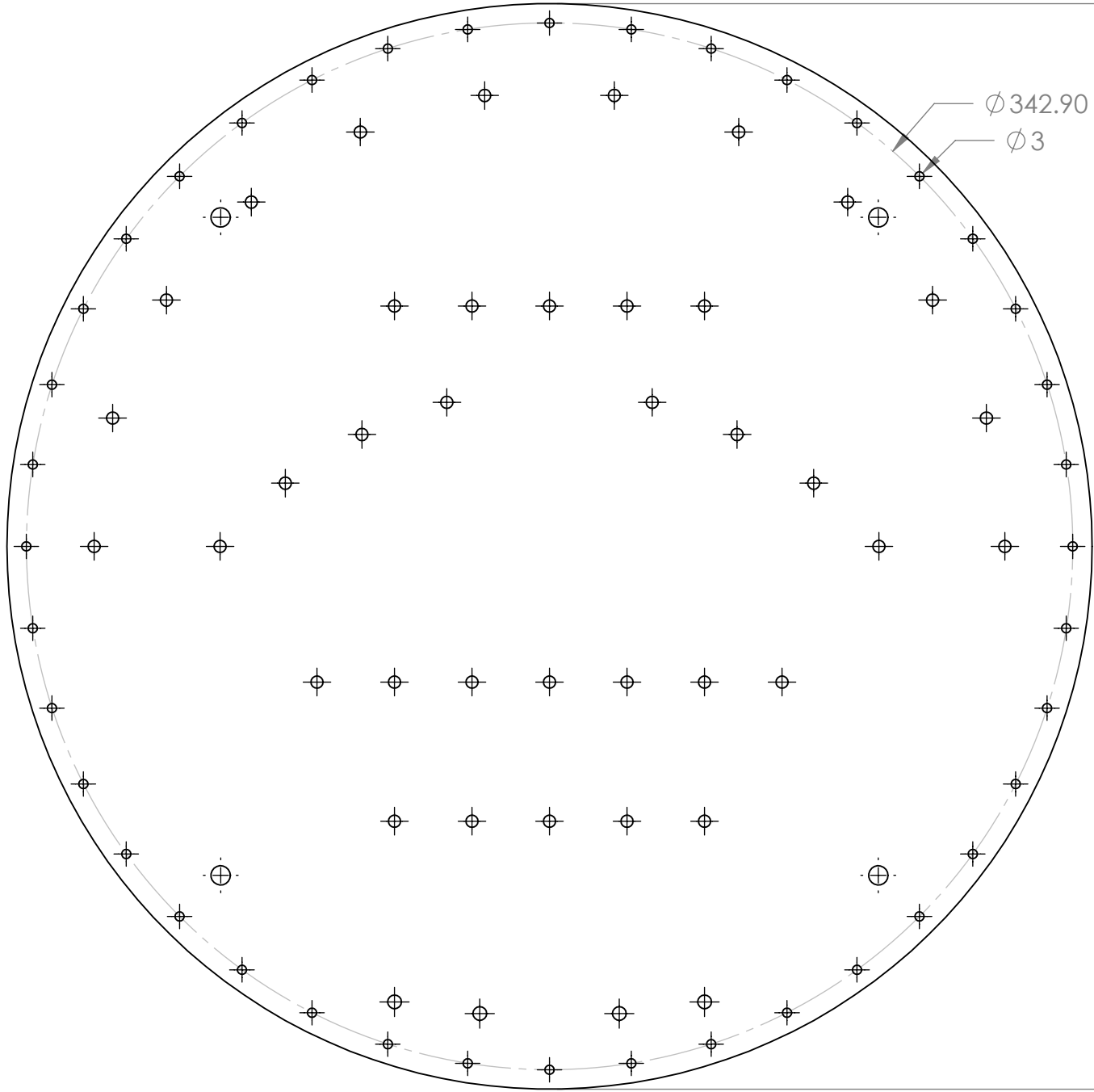

6.35

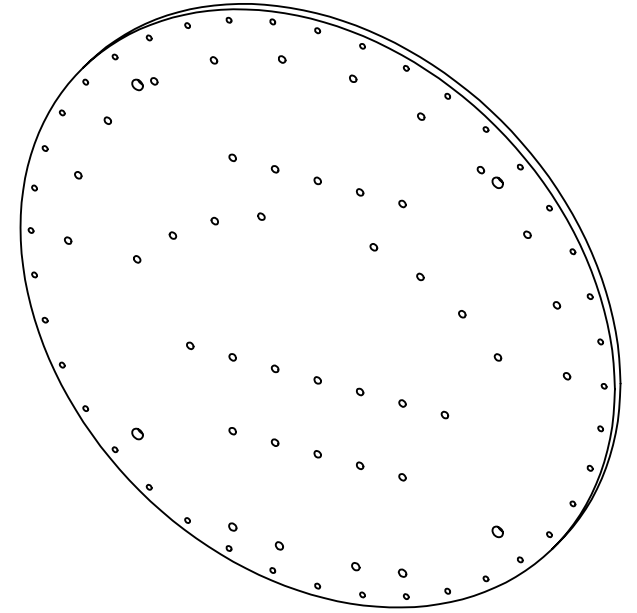

$\phi 355.60$

$\phi 342.90$
 $\phi 3$

B

B

A

A

PROPRIETARY AND CONFIDENTIAL
 THE INFORMATION CONTAINED IN THIS DRAWING IS THE SOLE PROPERTY OF <INSERT COMPANY NAME HERE>. ANY REPRODUCTION IN PART OR AS A WHOLE WITHOUT THE WRITTEN PERMISSION OF <INSERT COMPANY NAME HERE> IS PROHIBITED.

		UNLESS OTHERWISE SPECIFIED:		NAME	DATE		
		DIMENSIONS ARE IN INCHES		DRAWN		TITLE:	
		TOLERANCES:		CHECKED			
		FRACTIONAL \pm		ENG APPR.			
		ANGULAR: MACH \pm BEND \pm		MFG APPR.			
		TWO PLACE DECIMAL \pm		Q.A.		SIZE DWG. NO. REV B Top Chassis	
		THREE PLACE DECIMAL \pm		COMMENTS:			
		INTERPRET GEOMETRIC TOLERANCING PER:					
		MATERIAL					
		FINISH					
NEXT ASSY	USED ON	APPLICATION		DO NOT SCALE DRAWING		SCALE: 1:2 WEIGHT: SHEET 1 OF 1	

4

3

2

1

4

3

2

1

B

B

A

A

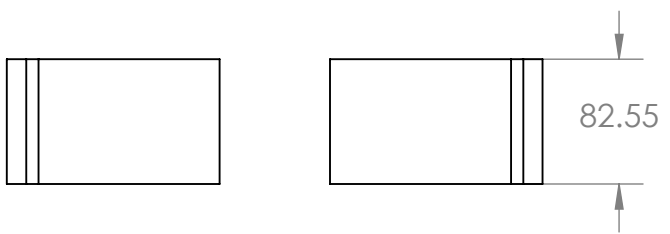
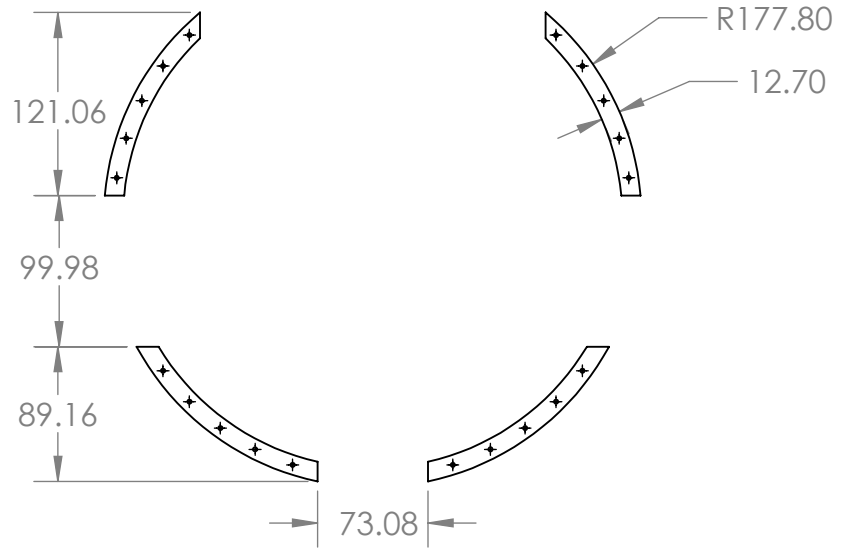
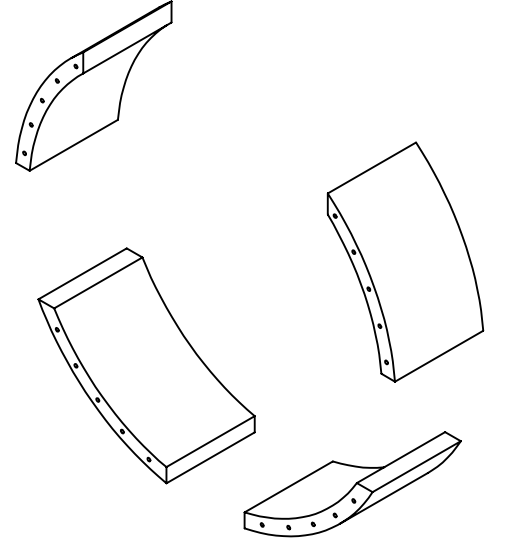
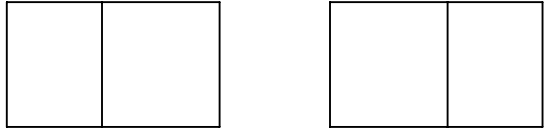

PROPRIETARY AND CONFIDENTIAL
 THE INFORMATION CONTAINED IN THIS DRAWING IS THE SOLE PROPERTY OF <INSERT COMPANY NAME HERE>. ANY REPRODUCTION IN PART OR AS A WHOLE WITHOUT THE WRITTEN PERMISSION OF <INSERT COMPANY NAME HERE> IS PROHIBITED.

		UNLESS OTHERWISE SPECIFIED:		NAME	DATE	
		DIMENSIONS ARE IN INCHES	DRAWN			TITLE:
		TOLERANCES:	CHECKED			
		FRACTIONAL ±	ENG APPR.			
		ANGULAR: MACH ± BEND ±	MFG APPR.			
		TWO PLACE DECIMAL ±	Q.A.			SIZE DWG. NO. REV
		THREE PLACE DECIMAL ±	COMMENTS:			B Junior Sides
		INTERPRET GEOMETRIC TOLERANCING PER:				SCALE: 1:5 WEIGHT: SHEET 1 OF 1
		MATERIAL				
NEXT ASSY	USED ON	FINISH				
APPLICATION		DO NOT SCALE DRAWING				

4

3

2

1

4

3

2

1

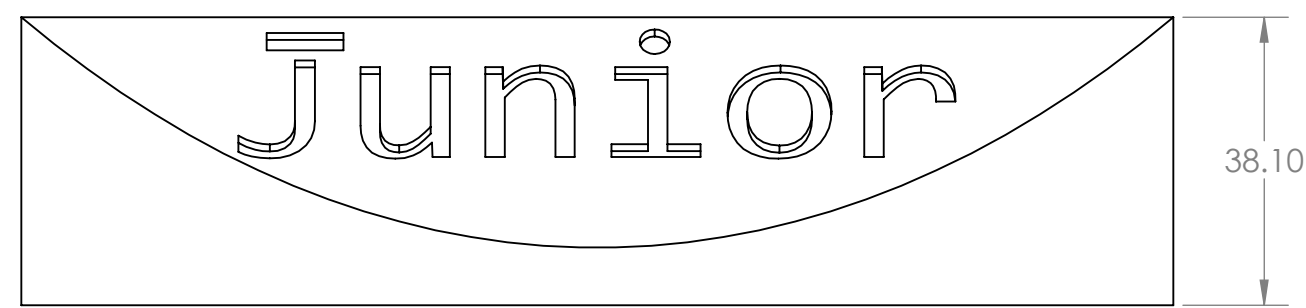
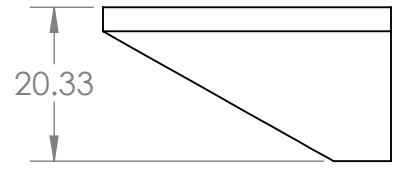
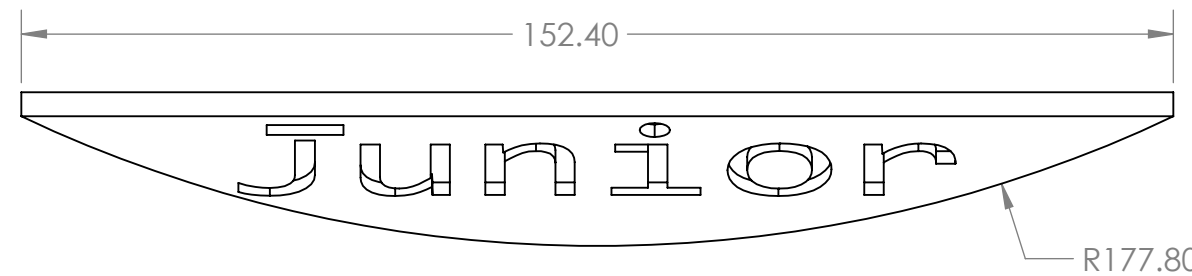
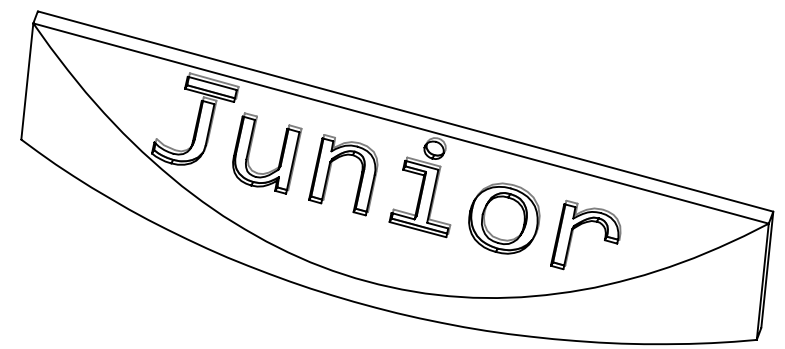

B

B

A

A

PROPRIETARY AND CONFIDENTIAL
 THE INFORMATION CONTAINED IN THIS DRAWING IS THE SOLE PROPERTY OF <INSERT COMPANY NAME HERE>. ANY REPRODUCTION IN PART OR AS A WHOLE WITHOUT THE WRITTEN PERMISSION OF <INSERT COMPANY NAME HERE> IS PROHIBITED.

		UNLESS OTHERWISE SPECIFIED:		NAME	DATE			
		DIMENSIONS ARE IN INCHES	DRAWN			TITLE:		
		TOLERANCES:	CHECKED					
		FRACTIONAL ±	ENG APPR.					
		ANGULAR: MACH ± BEND ±	MFG APPR.					
		TWO PLACE DECIMAL ±	Q.A.					
		THREE PLACE DECIMAL ±	COMMENTS:					
		INTERPRET GEOMETRIC TOLERANCING PER:				SIZE	DWG. NO.	REV
		MATERIAL				B Nameplate		
NEXT ASSY	USED ON	FINISH				SCALE: 1:1	WEIGHT:	SHEET 1 OF 1
APPLICATION		DO NOT SCALE DRAWING						

4

3

2

1

4

3

2

1

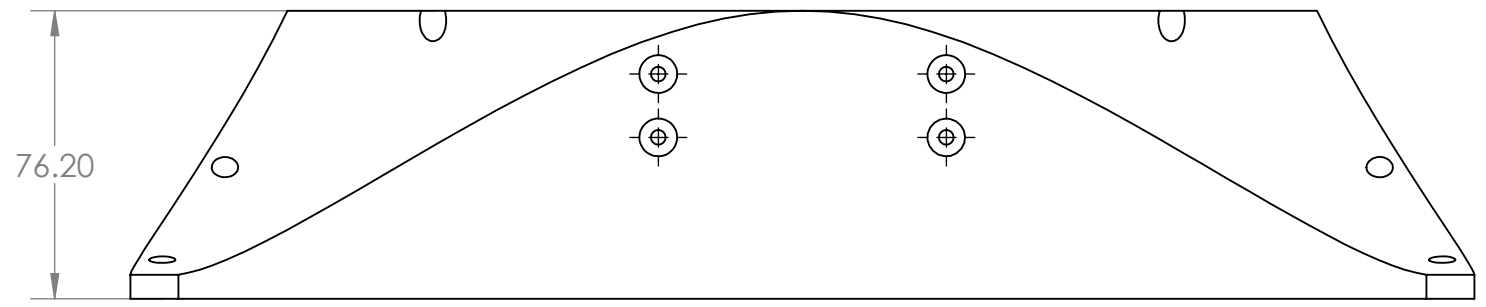
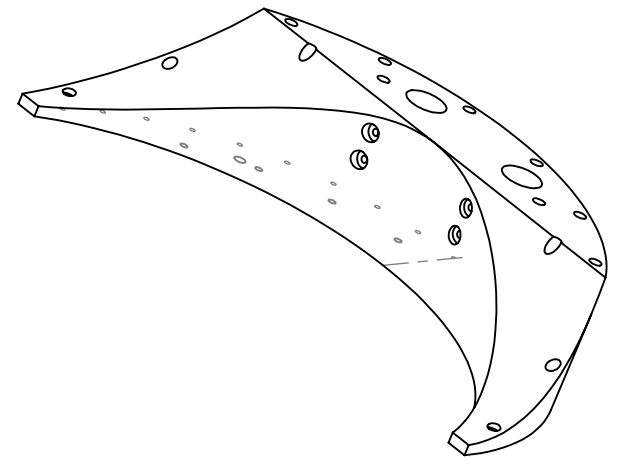
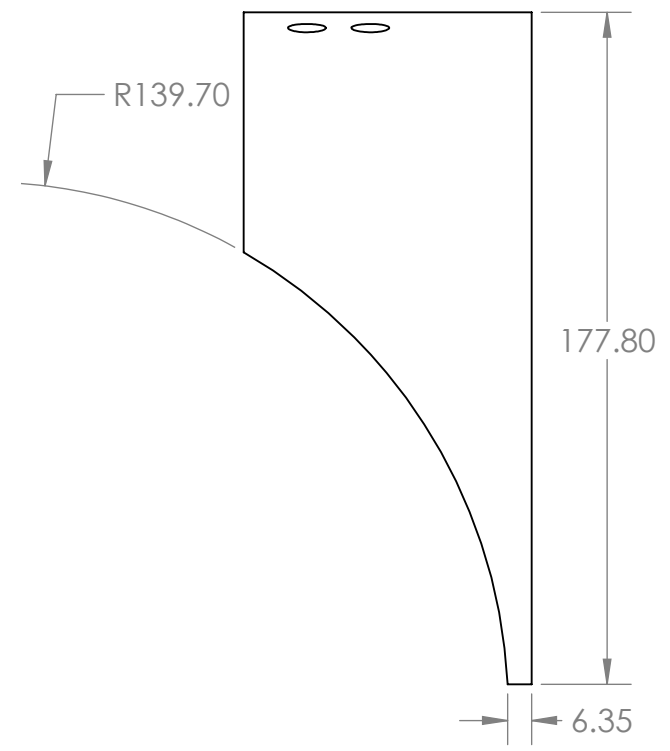
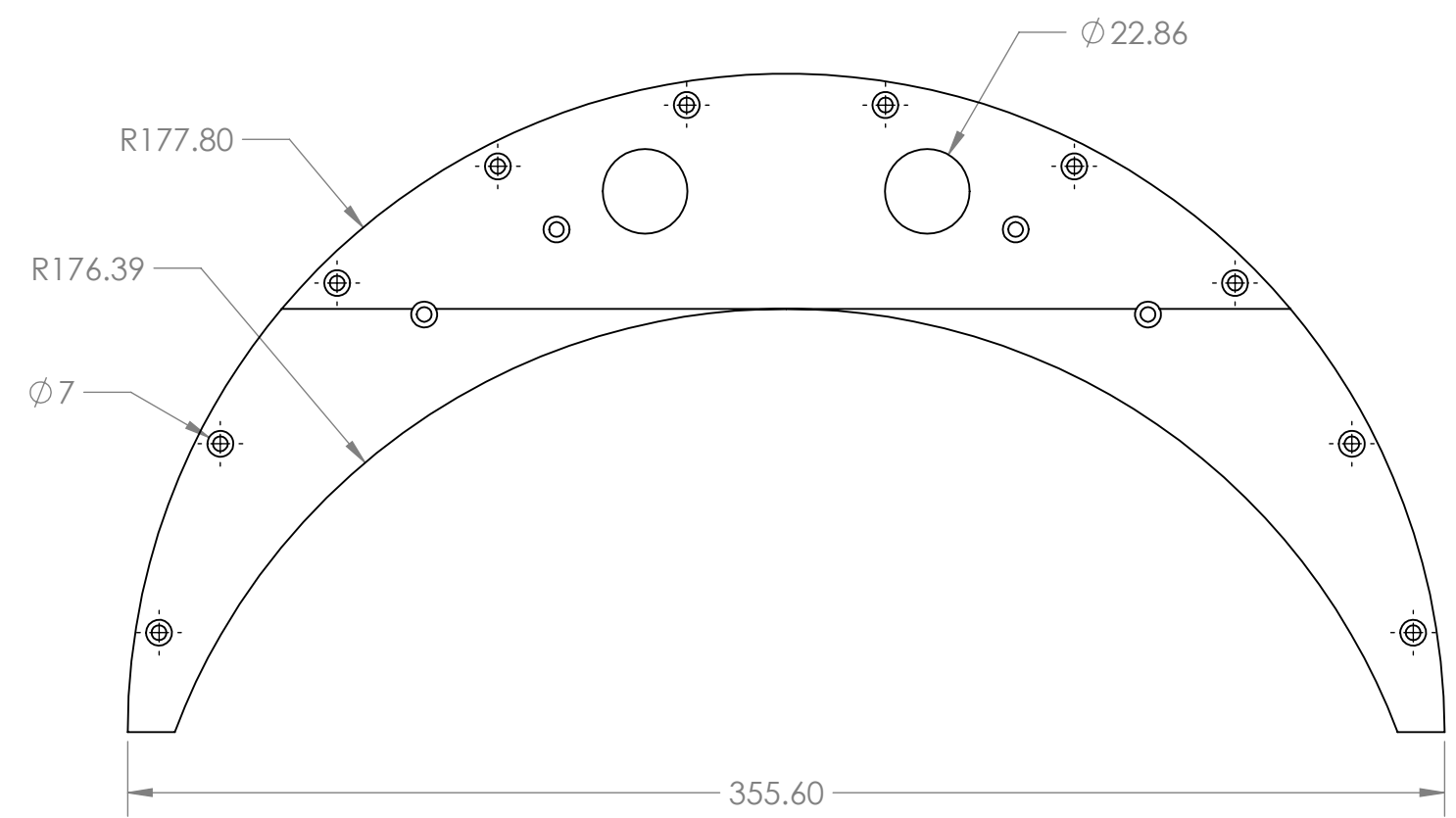

B

B

A

A

PROPRIETARY AND CONFIDENTIAL
 THE INFORMATION CONTAINED IN THIS DRAWING IS THE SOLE PROPERTY OF <INSERT COMPANY NAME HERE>. ANY REPRODUCTION IN PART OR AS A WHOLE WITHOUT THE WRITTEN PERMISSION OF <INSERT COMPANY NAME HERE> IS PROHIBITED.

		UNLESS OTHERWISE SPECIFIED:	NAME	DATE		
		DIMENSIONS ARE IN INCHES	DRAWN			
		TOLERANCES:	CHECKED		TITLE:	
		FRACTIONAL ±	ENG APPR.			
		ANGULAR: MACH ± BEND ±	MFG APPR.			
		TWO PLACE DECIMAL ±	Q.A.			
		THREE PLACE DECIMAL ±	COMMENTS:			
		INTERPRET GEOMETRIC TOLERANCING PER:				
		MATERIAL				
NEXT ASSY	USED ON	FINISH				
APPLICATION		DO NOT SCALE DRAWING				
SIZE	DWG. NO.	REV				
B	RodHolder					
SCALE: 1:2	WEIGHT:	SHEET 1 OF 1				

4

3

2

1

4

3

2

1

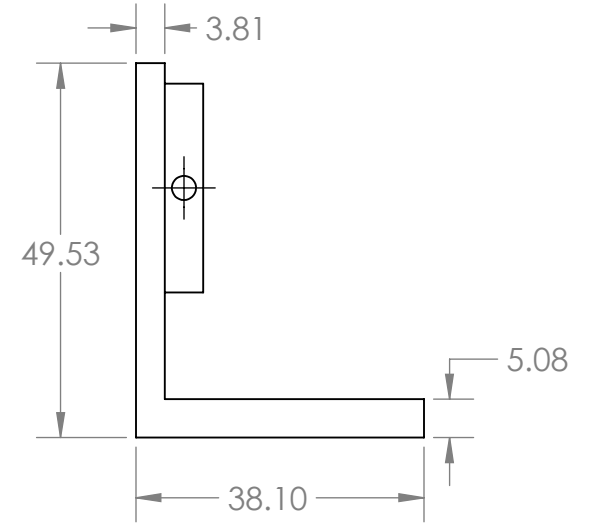
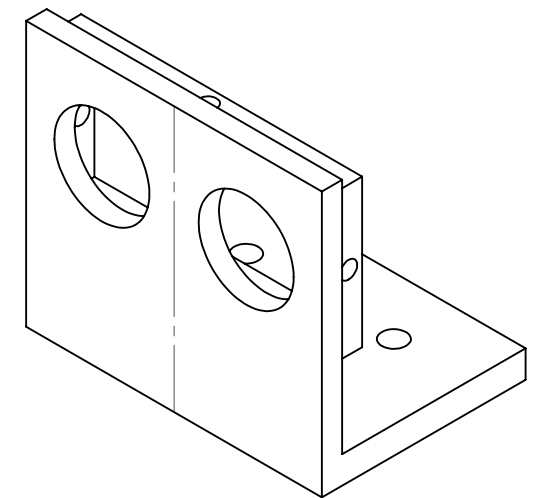
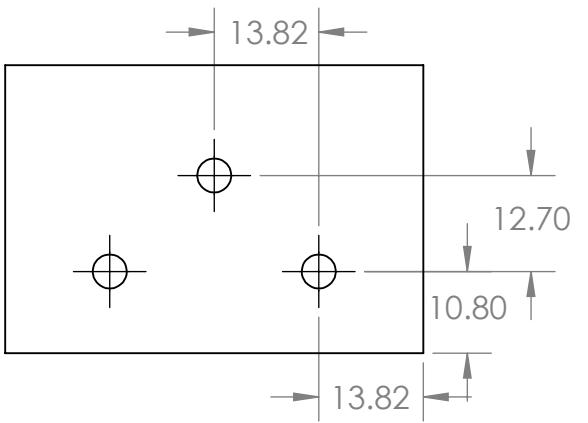
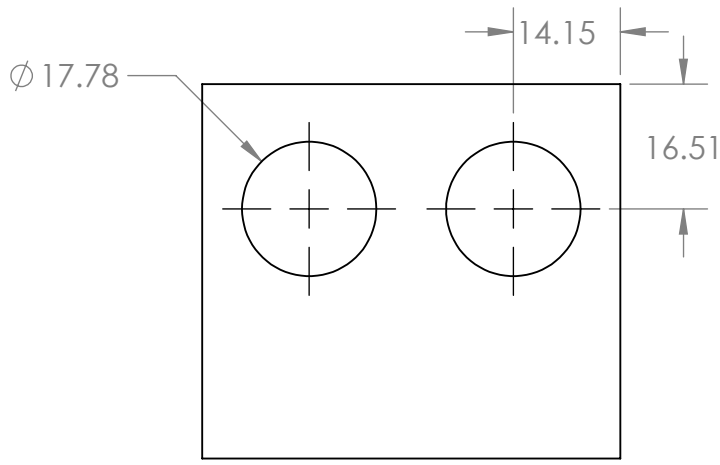
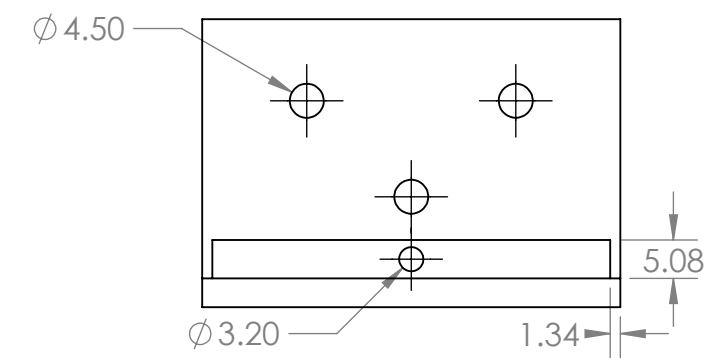

PROPRIETARY AND CONFIDENTIAL
 THE INFORMATION CONTAINED IN THIS DRAWING IS THE SOLE PROPERTY OF <INSERT COMPANY NAME HERE>. ANY REPRODUCTION IN PART OR AS A WHOLE WITHOUT THE WRITTEN PERMISSION OF <INSERT COMPANY NAME HERE> IS PROHIBITED.

		UNLESS OTHERWISE SPECIFIED:	NAME	DATE		
		DIMENSIONS ARE IN INCHES	DRAWN		TITLE:	
		TOLERANCES:	CHECKED			
		FRACTIONAL \pm	ENG APPR.			
		ANGULAR: MACH \pm BEND \pm	MFG APPR.			
		TWO PLACE DECIMAL \pm	Q.A.		SIZE DWG. NO. REV B ultraSonic_Mount	
		THREE PLACE DECIMAL \pm	COMMENTS:			
		INTERPRET GEOMETRIC TOLERANCING PER:				SCALE: 1:1
		MATERIAL				WEIGHT:
NEXT ASSY	USED ON	FINISH				SHEET 1 OF 1
APPLICATION		DO NOT SCALE DRAWING				

4

3

2

1

B

B

A

A

4

3

2

1

B

B

A

A

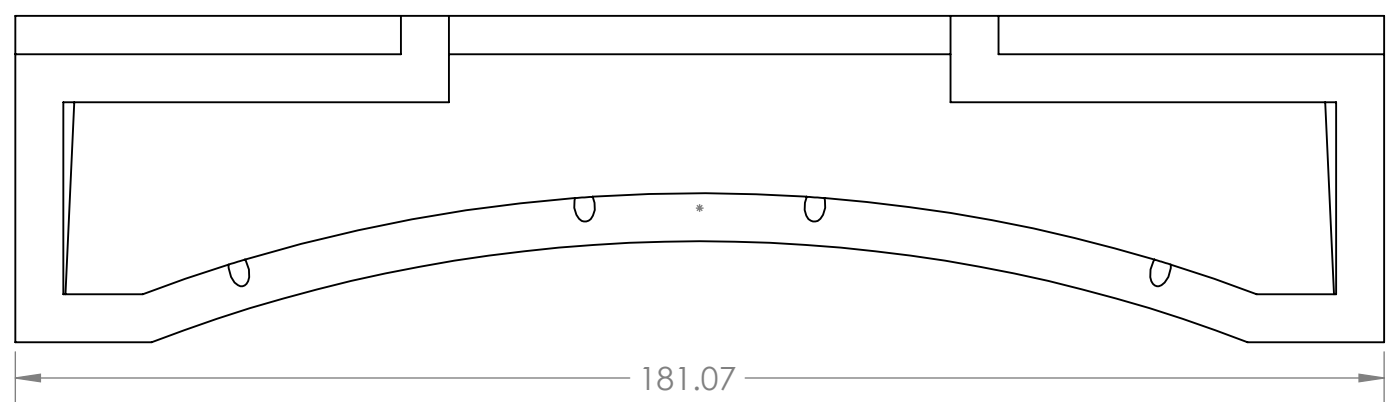
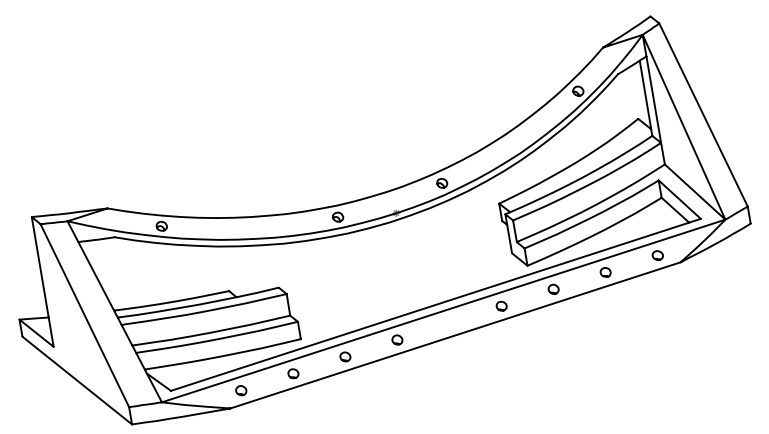
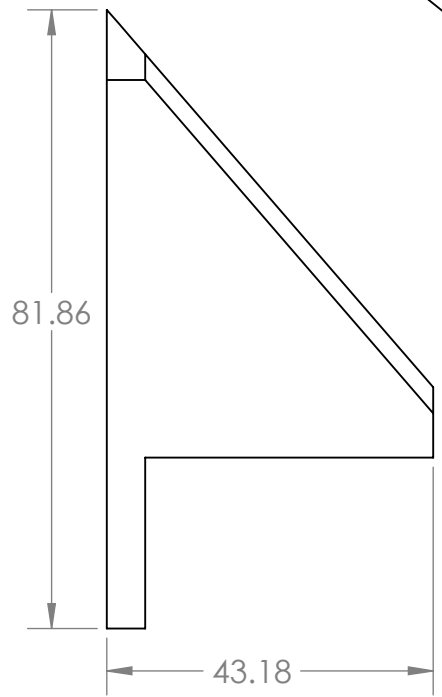
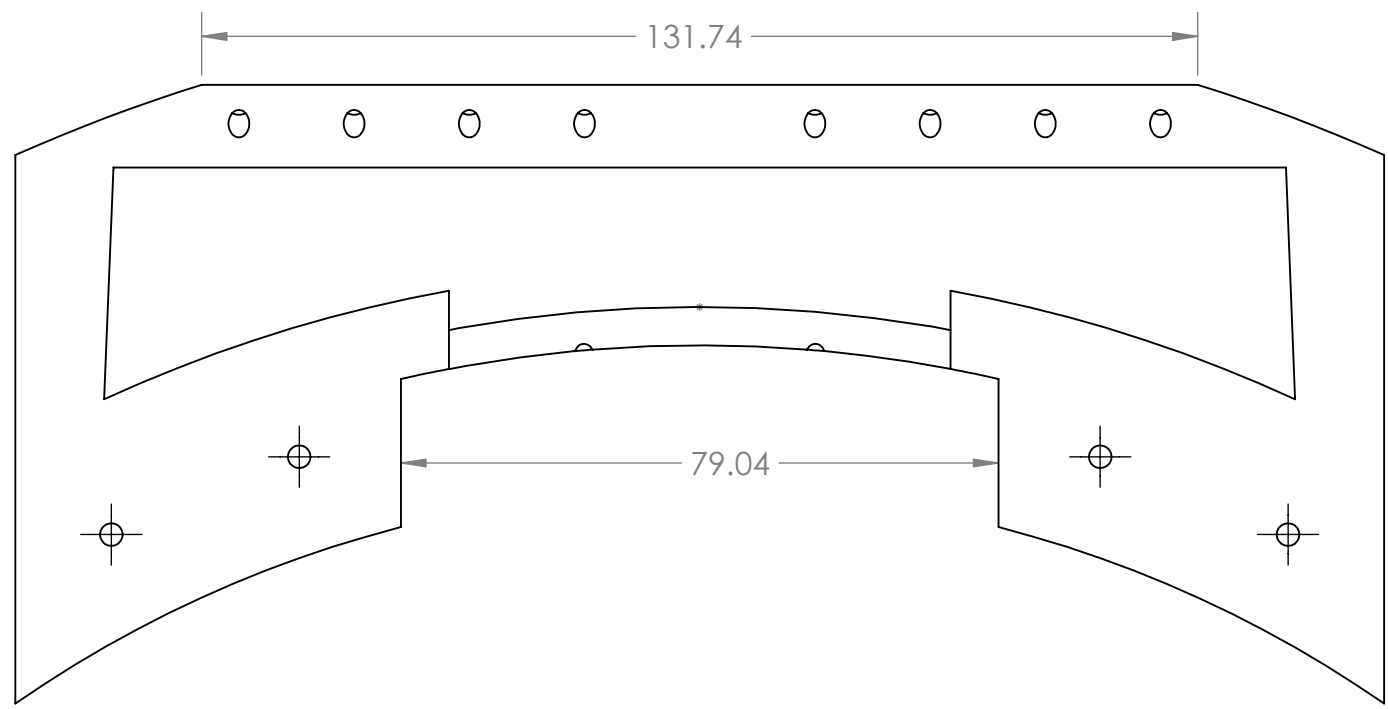

PROPRIETARY AND CONFIDENTIAL
 THE INFORMATION CONTAINED IN THIS DRAWING IS THE SOLE PROPERTY OF <INSERT COMPANY NAME HERE>. ANY REPRODUCTION IN PART OR AS A WHOLE WITHOUT THE WRITTEN PERMISSION OF <INSERT COMPANY NAME HERE> IS PROHIBITED.

		UNLESS OTHERWISE SPECIFIED:	NAME	DATE		
		DIMENSIONS ARE IN INCHES	DRAWN		TITLE:	
		TOLERANCES:	CHECKED			
		FRACTIONAL ±	ENG APPR.			
		ANGULAR: MACH ± BEND ±	MFG APPR.			
		TWO PLACE DECIMAL ±	Q.A.		SIZE DWG. NO. REV B Switchboard	
		THREE PLACE DECIMAL ±	COMMENTS:			
		INTERPRET GEOMETRIC TOLERANCING PER:				SCALE: 1:1
		MATERIAL				WEIGHT:
NEXT ASSY	USED ON	FINISH				SHEET 1 OF 1
APPLICATION		DO NOT SCALE DRAWING				

4

3

2

1

4

3

2

1

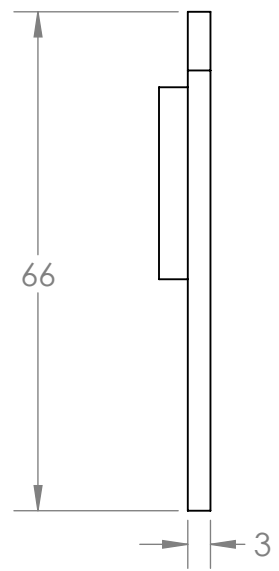
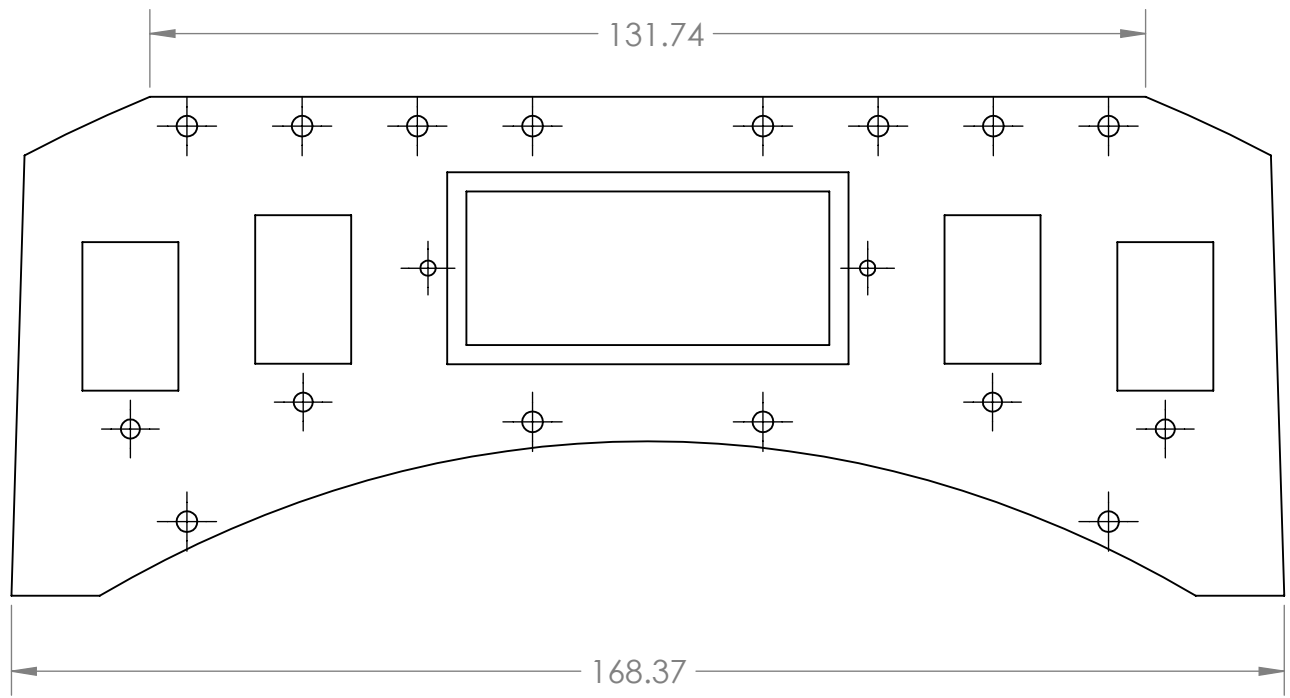
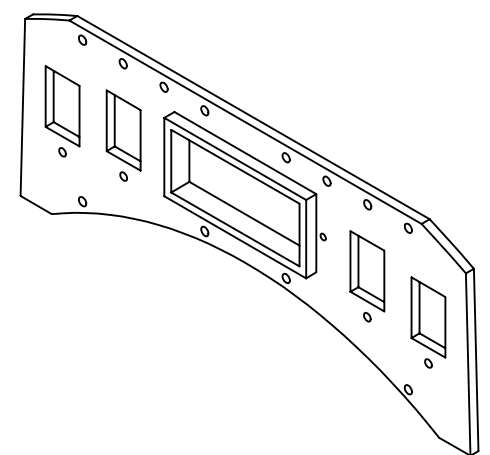

B

B

A

A

PROPRIETARY AND CONFIDENTIAL
 THE INFORMATION CONTAINED IN THIS DRAWING IS THE SOLE PROPERTY OF <INSERT COMPANY NAME HERE>. ANY REPRODUCTION IN PART OR AS A WHOLE WITHOUT THE WRITTEN PERMISSION OF <INSERT COMPANY NAME HERE> IS PROHIBITED.

		UNLESS OTHERWISE SPECIFIED:	NAME	DATE		
		DIMENSIONS ARE IN INCHES	DRAWN		TITLE:	
		TOLERANCES:	CHECKED			
		FRACTIONAL ±	ENG APPR.			
		ANGULAR: MACH ± BEND ±	MFG APPR.			
		TWO PLACE DECIMAL ±	Q.A.		SIZE DWG. NO. REV B Switch Panel	
		THREE PLACE DECIMAL ±	COMMENTS:			
		INTERPRET GEOMETRIC TOLERANCING PER:				
		MATERIAL				
NEXT ASSY	USED ON	FINISH				
APPLICATION		DO NOT SCALE DRAWING	SCALE: 1:1 WEIGHT: SHEET 1 OF 1			

4

3

2

1

4

3

2

1

B

B

A

A

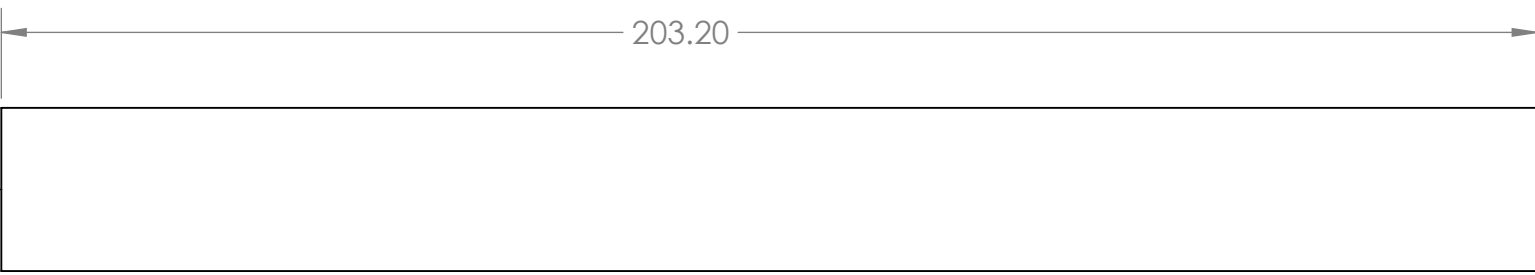
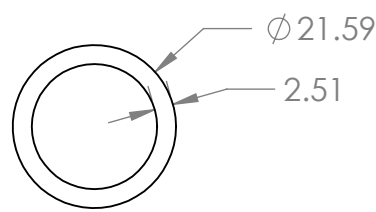
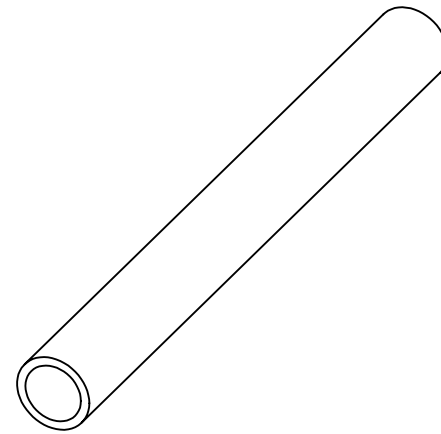

PROPRIETARY AND CONFIDENTIAL
 THE INFORMATION CONTAINED IN THIS DRAWING IS THE SOLE PROPERTY OF <INSERT COMPANY NAME HERE>. ANY REPRODUCTION IN PART OR AS A WHOLE WITHOUT THE WRITTEN PERMISSION OF <INSERT COMPANY NAME HERE> IS PROHIBITED.

		UNLESS OTHERWISE SPECIFIED:		NAME	DATE	TITLE:
		DIMENSIONS ARE IN INCHES	DRAWN			
		TOLERANCES:	CHECKED			
		FRACTIONAL \pm	ENG APPR.			
		ANGULAR: MACH \pm BEND \pm	MFG APPR.			SIZE DWG. NO. REV B Kinect Poles
		TWO PLACE DECIMAL \pm	Q.A.			
		THREE PLACE DECIMAL \pm	COMMENTS:			SCALE: 1:1 WEIGHT: SHEET 1 OF 1
		INTERPRET GEOMETRIC TOLERANCING PER:				
		MATERIAL				
		FINISH				
NEXT ASSY	USED ON					
APPLICATION		DO NOT SCALE DRAWING				

4

3

2

1

4

3

2

1

B

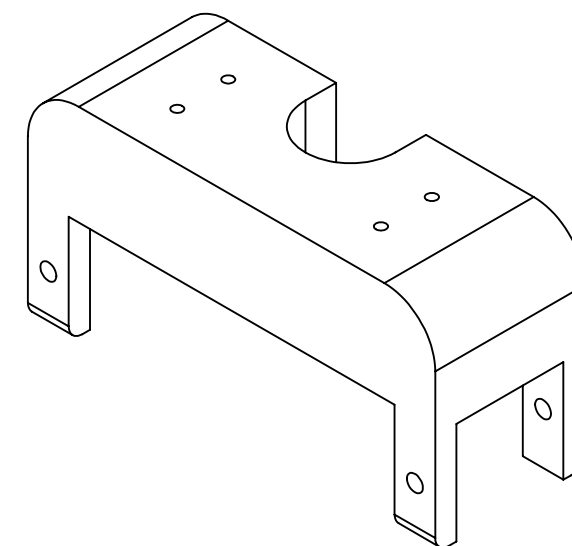
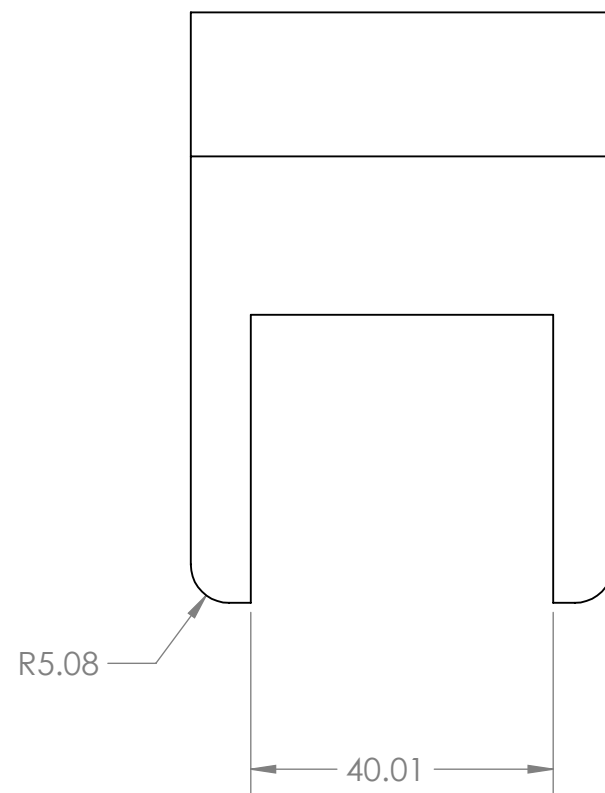
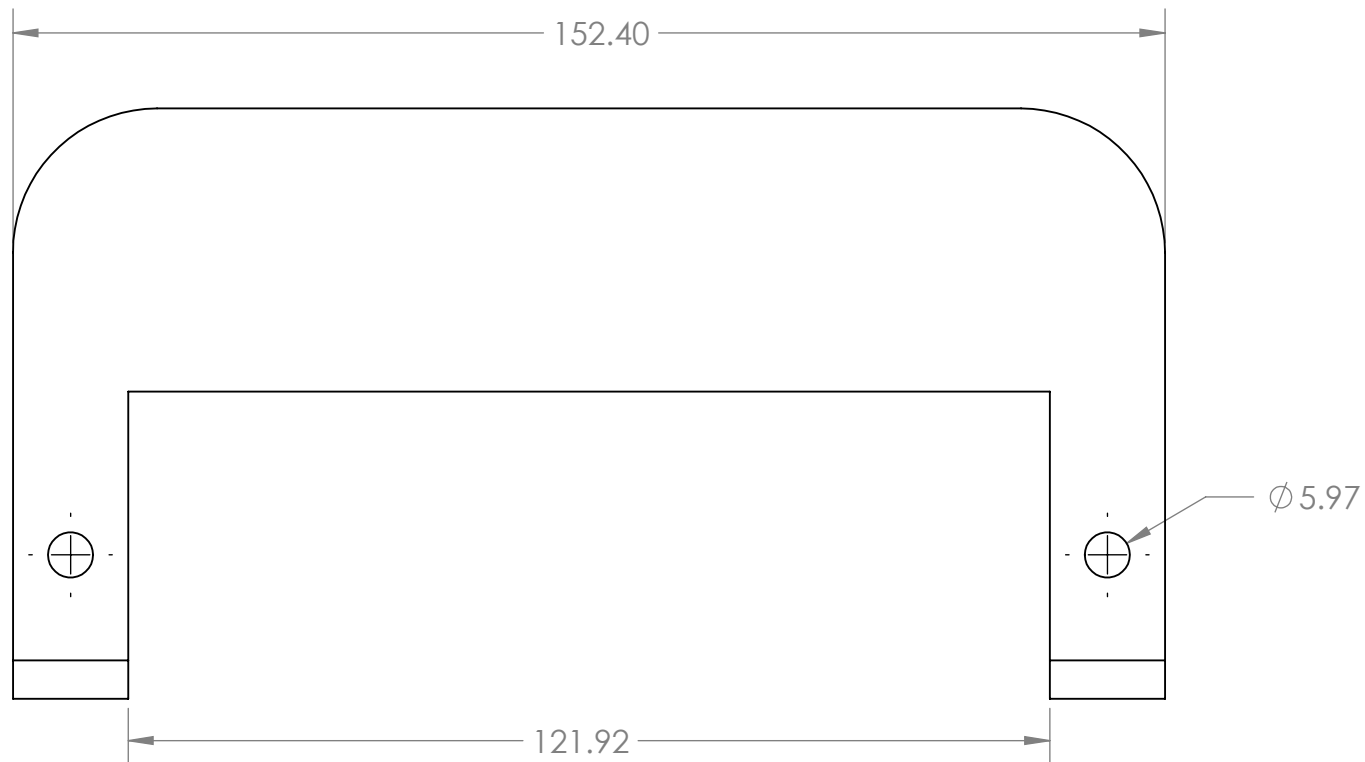

B

A

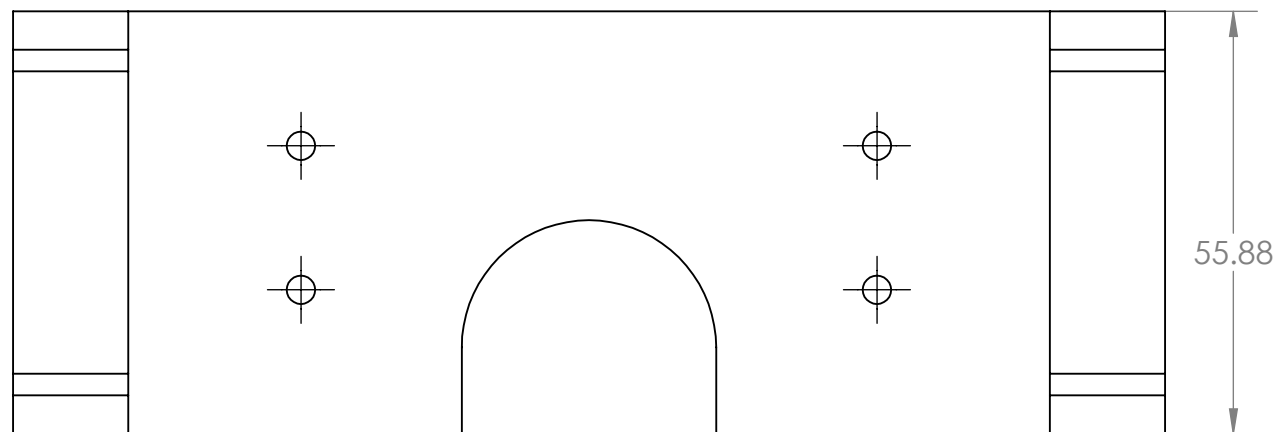

A

PROPRIETARY AND CONFIDENTIAL
 THE INFORMATION CONTAINED IN THIS DRAWING IS THE SOLE PROPERTY OF <INSERT COMPANY NAME HERE>. ANY REPRODUCTION IN PART OR AS A WHOLE WITHOUT THE WRITTEN PERMISSION OF <INSERT COMPANY NAME HERE> IS PROHIBITED.

		UNLESS OTHERWISE SPECIFIED:		NAME	DATE	
		DIMENSIONS ARE IN INCHES	DRAWN			TITLE:
		TOLERANCES:	CHECKED			
		FRACTIONAL ±	ENG APPR.			
		ANGULAR: MACH ± BEND ±	MFG APPR.			
		TWO PLACE DECIMAL ±	Q.A.			SIZE DWG. NO. REV B Kinect Mount
		THREE PLACE DECIMAL ±	COMMENTS:			
		INTERPRET GEOMETRIC TOLERANCING PER:				SCALE: 1:1 WEIGHT: SHEET 1 OF 1
		MATERIAL				
NEXT ASSY	USED ON	FINISH				
APPLICATION		DO NOT SCALE DRAWING				

4

3

2

1